

IRONMAN®

Owner's Manual

VIPER

Customer Service

1.800.750.IRON

1.800.750.4766

IRONMAN
Fitness

4009 Distribution Drive
Suite 250
Garland, TX 75041

www.ironmanfitness.com

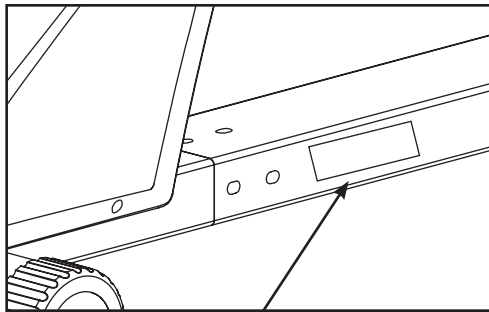

SERIAL TAG IS LOCATED ON THE FRAME

Model Name: Viper

Date of Purchase: _____

Serial Number: _____

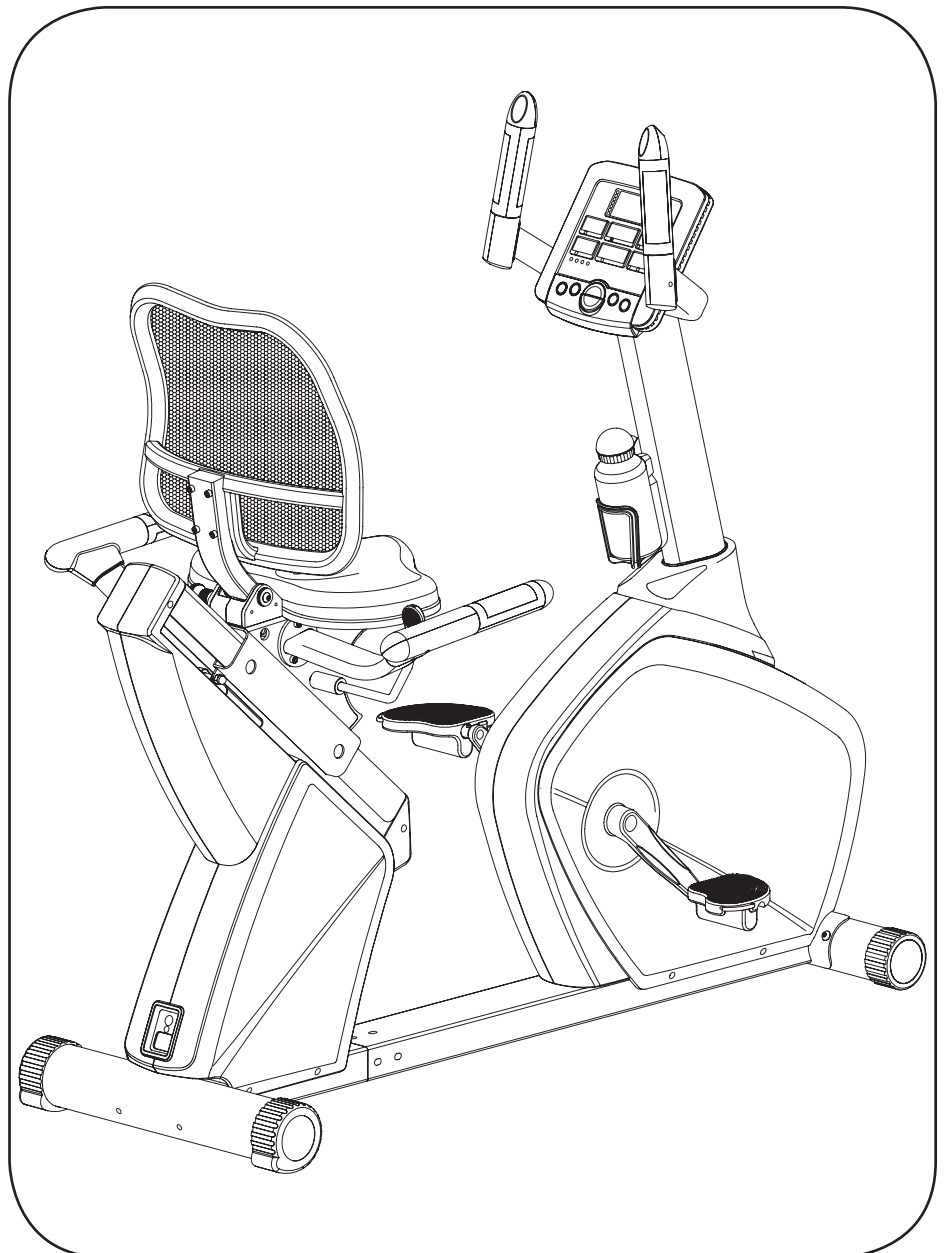

315-00109
07/07 Rev A

Table of Contents



Important Safety Information	3-4
Parts Identifier	5-6
Assembly	7-12
Console Instructions	13-17
Monitoring Your Heart Rate	18
Warm-Up Exercises	19
General Instructions	20
Moving Instructions	21
Parts List	22
Exploded Views	23
Warranty Information	24

Important Safety Information



WARNING! Before using this unit or starting any exercise program, consult your physician. This is especially important for persons over the age of 35 and/or persons with pre-existing health problems. The manufacturer or distributor assumes no responsibility for personal injury or property damage sustained by or through the use of this product.

WARNING! To reduce the risk of electrical shock, burns, fire, or other possible injuries to the user, it is important to review this manual and the following precautions before operation.

SAFETY PRECAUTIONS AND TIPS

1. It is the owner's responsibility to ensure that all users of this unit have read the Owner's Manual and are familiar with warnings and safety precautions.
2. This unit has a user maximum capacity of **300** pounds.
3. The unit should only be used on a level surface and is intended for indoor use only. The unit should not be placed in a garage, patio, or near water and should never be used while you are wet. Ironman Fitness recommends a mat be placed under the unit to protect floor or carpet and for easier cleaning.
4. Follow safety information in regards to plugging in your unit. Do not run the power cord underneath your unit. Do not operate the unit with a damaged or frayed power cord.
5. Wear comfortable, good-quality walking or running shoes and appropriate clothing. Do not use the unit with bare feet, sandals, socks or stockings.
6. Always examine your unit before using to ensure all parts are in working order.
7. Allow the unit to fully stop before dismounting.
8. Pets should never be allowed near the unit.
9. Do not leave children unsupervised near or on the unit.
10. Never operate the unit where oxygen is being administered, or where aerosol products are being used.
11. Never insert any object or body parts into any opening.
12. For safety and to prevent damage to your unit, no more than one person should use the unit at a time.
13. Always unplug the unit before cleaning and/or servicing. Service to your unit should only be performed by an authorized service representative, unless authorized and/or instructed by the manufacturer.
14. Failure to follow these instructions will void the unit warranty.

Important Safety Information



Thank you for purchasing the Ironman Fitness **Viper Recumbent Bike!** The quality product you have chosen was designed to meet your needs for cardiovascular exercise. Before you start, please read the Owner's Manual and become familiar with the operation of your new unit. Remember to take time to perform stretching exercises, provided in this manual, to help avoid injury.

If you are taking medication, consult your physician to see what effect the medication will have on your exercise heart rate.

If you have heart problems, you are not active, and/or are over the age of 35 years, do not use the pre-set programs or start an exercise program without first contacting and receiving approval from your physician.

To avoid the risk of electrical shock, always keep the console dry. Do not spill liquids on the console. Ironman Fitness recommends a sealed water bottle for beverages consumed while using the unit.

Please review the following drawing below to familiarize yourself with the listed parts.

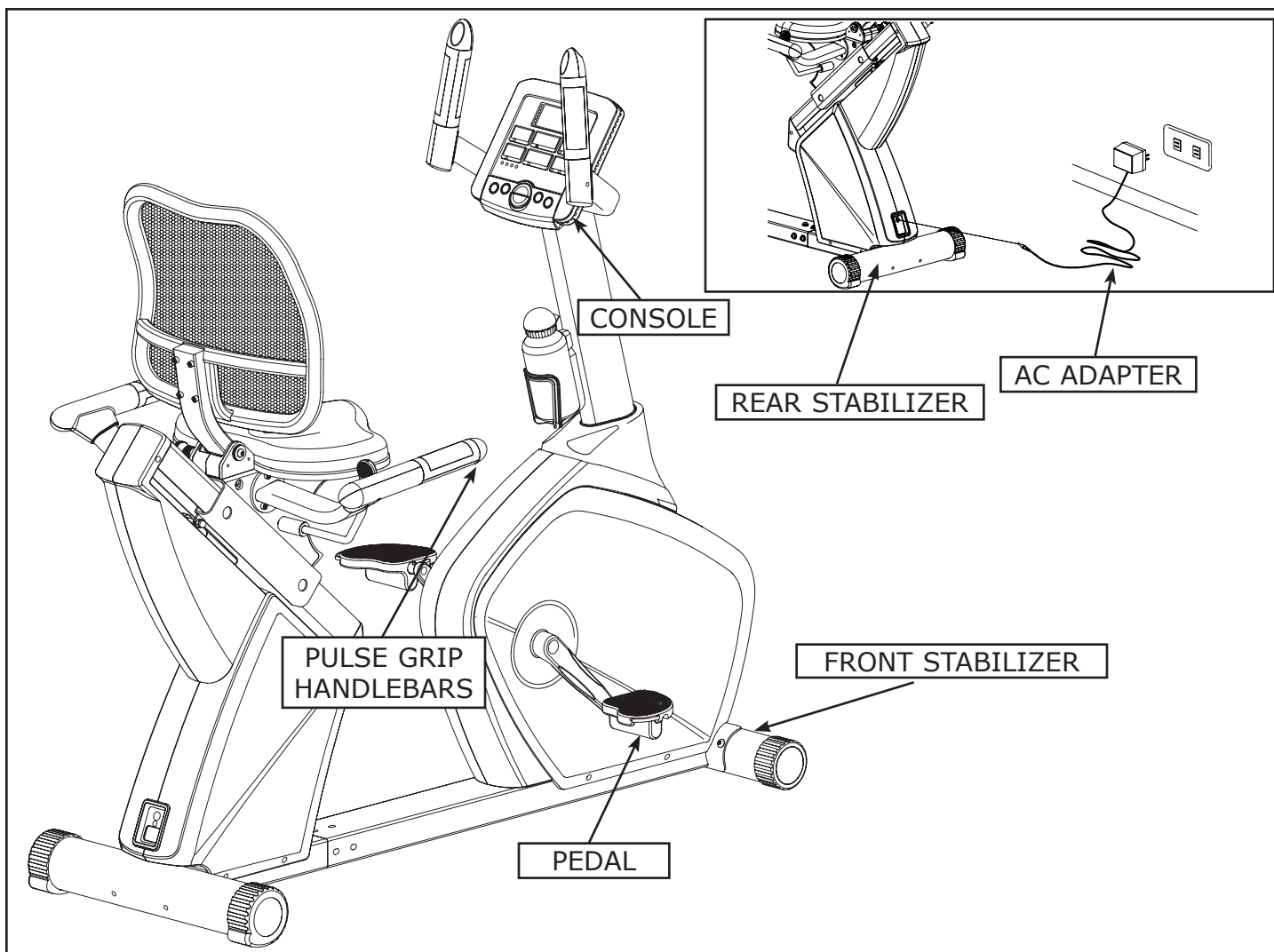

Parts Identifier

INSTRUCTIONS FOR ASSEMBLY:

Unpack the box in a clear area. Check to make sure all components are present and in good condition. Do not dispose of the packing material until the assembly is completed. Tools have been provided for you to use when assembling this product.

Locate the hardware pack and identify the following parts required for assembly.

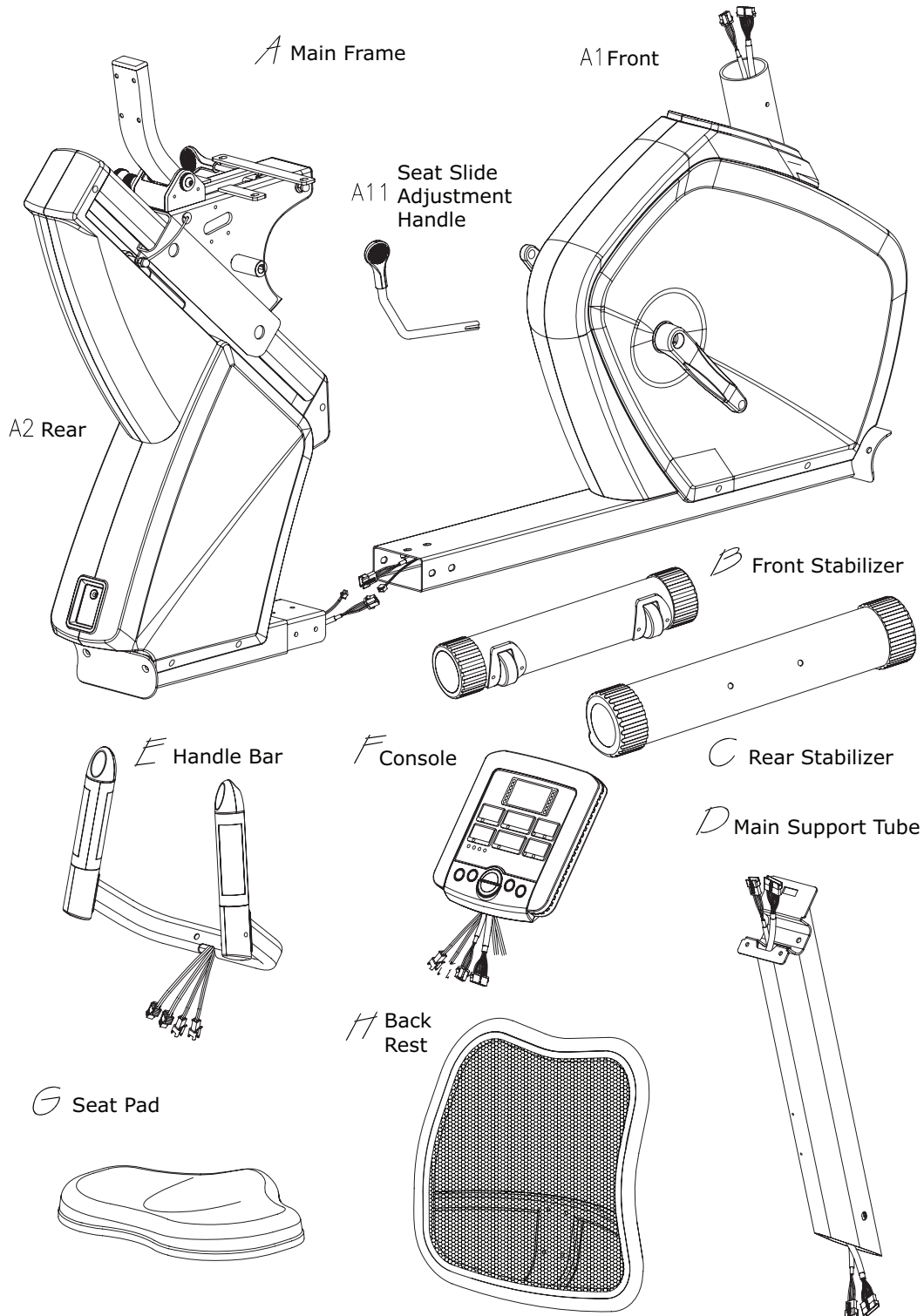

INSTRUCTIONS FOR ASSEMBLY:

Unpack the box in a clear area. Check to make sure all components are present and in good condition. Do not dispose of the packing material until the assembly is completed. Tools have been provided for you to use when assembling this product.

/ Decoration Cover

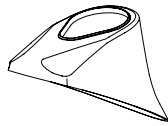

✓ Side Handle bars

J-(L)

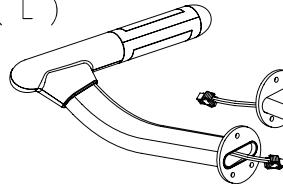

J-(R)

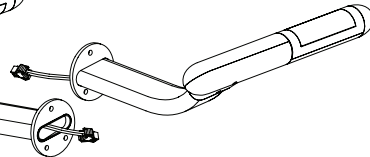

K Water Bottle Set

K1-Bottle Holder

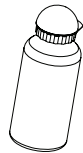

K2-Water Bottle

K3-Screw
M5x15m/m



L Pedal

L-(L)

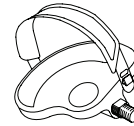

L-(R)

M Adapter

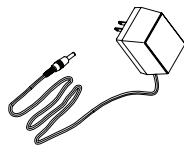

Tools

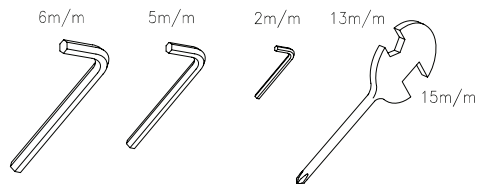

N Screw Bag

(N1)-Screw
M8x16Lx16pcs



(N2)-Spring Washer
M8x6pcs



(N2)-Washer
M8x6pcs

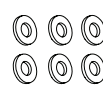

(N3)-Screw
M8x95Lx2pcs

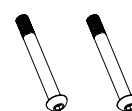

(N4)-Screw
M8x35Lx2pcs



(N5)-Screw
1/4"x40Lx4pcs



(N6)-Screw
M6x12Lx6pcs



(N9)-Washer
M8x2pcs



(N10)-Screw
M6x8L



Assembly

Getting Started - The Ironman Fitness Viper Recumbent Bike will require some assembly. Unpack the box in a clear area. Remove packing material. Do not dispose of packing material until assembly is complete and unit is working properly. Place the unit on a clean level surface for assembly. Make sure there is easy access to an electrical outlet. Before assembling, the unit should be placed as close as possible to its final location. If you are missing any parts, please call Ironman Fitness at 1-800-750-4766. Tools have been provided to assist with product assembly.

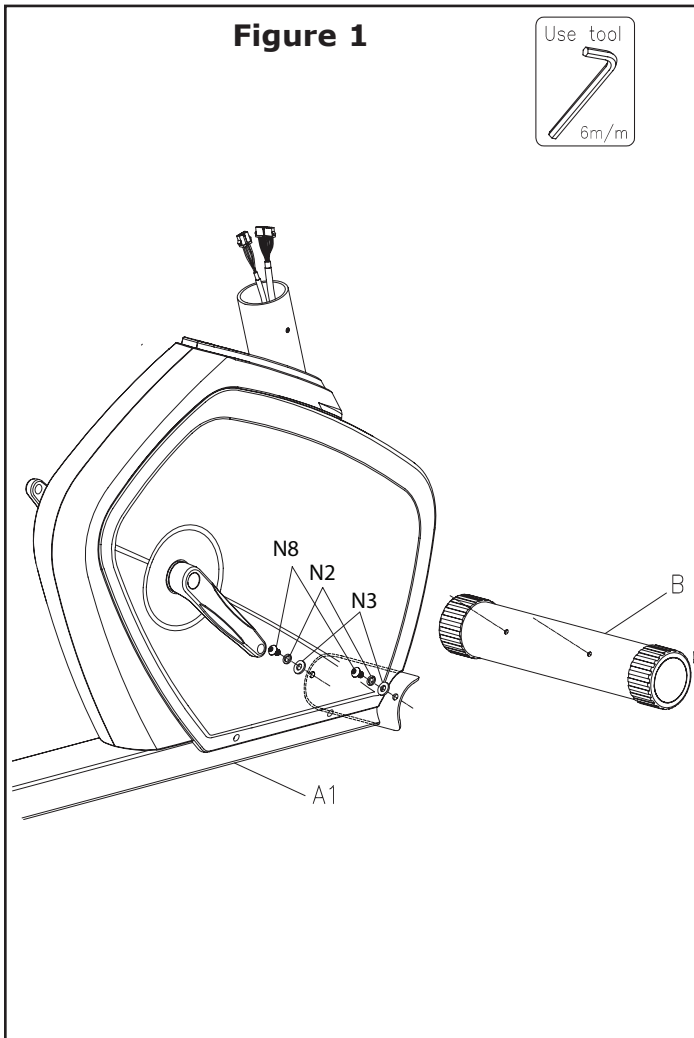

Figure 1
Step 1:

Secure front stabilizer bar (B) to main frame (A1) using two bolts (N1), spring washers (N2) and two washers (N3).

Note: Bolts will already be installed onto the front stabilizer.

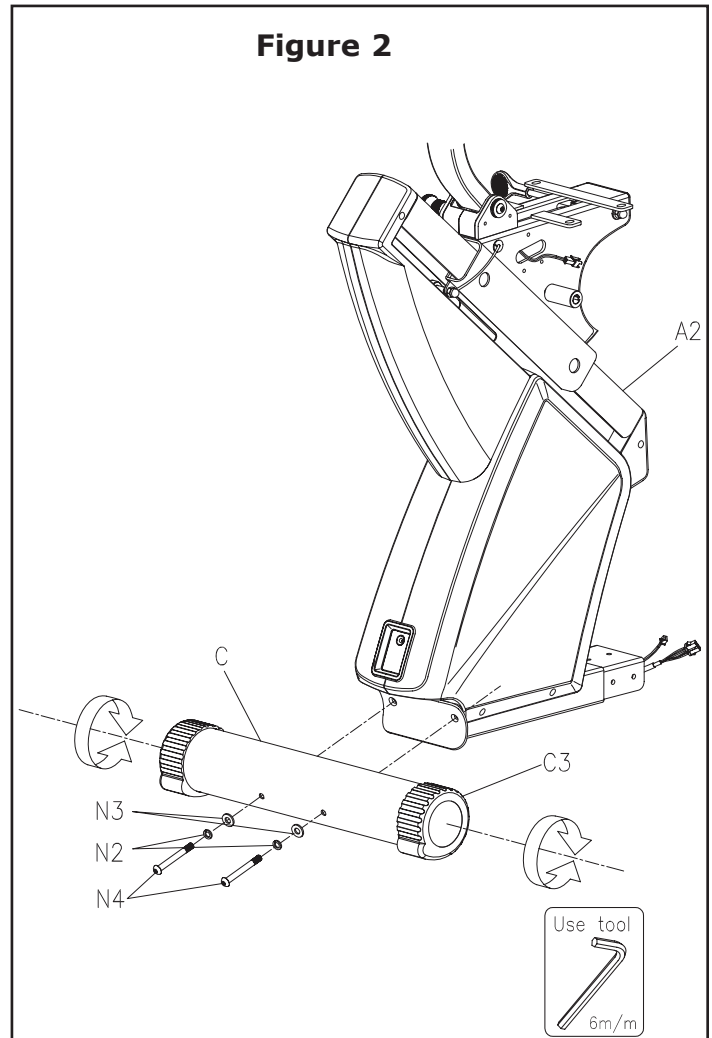

Figure 2
Step 1:

Secure rear stabilizer (C) to the main frame (A2) using bolts (N4), two spring washers (N2) and two washers (N3), already attached to stabilizer.

Figure 3

Step 1:

Connect hand pulse sensor wire-rear (A24) to the hand pulse sensor wire-middle (A23). Connect the power cord (A31) to power cord (A32).

Step 2:

Locate the front (A1) and rear (A2) main frames. Connect both front and rear frames. To secure, use six bolts (N1), six spring washers (N2) and six washers (N3) - make sure all holes are lined up correctly.

Note: Ensure that all wires are secure inside tube during the entire time both frames are being secured. Be careful not to pinch wires.

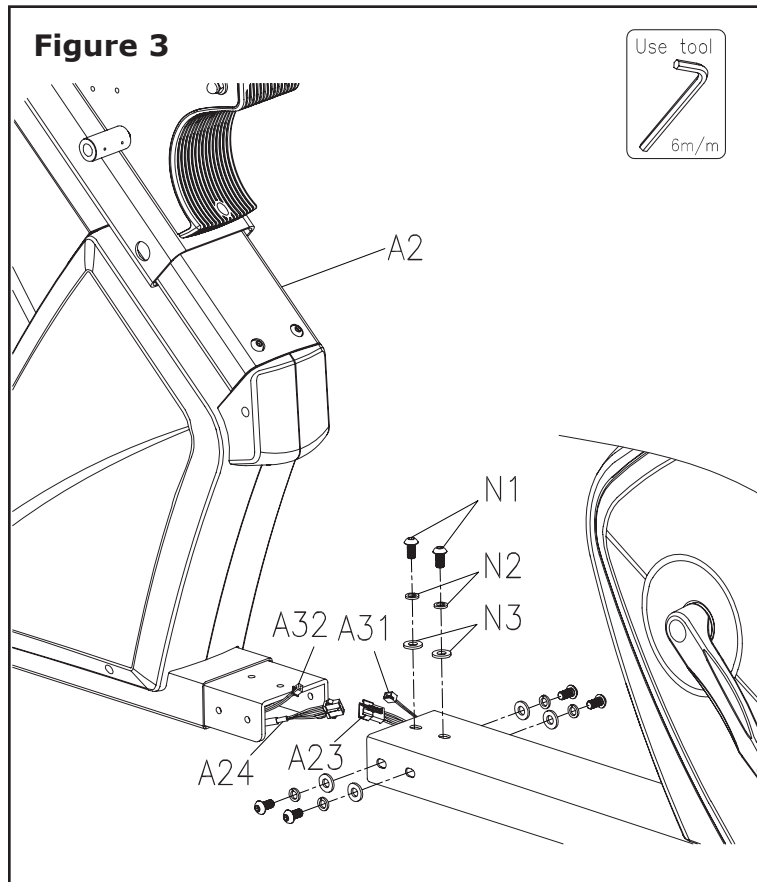

Figure 4

Step 1:

Locate main support tube (D) and console tube cover (I). Slide main tube cover up the main support tube.

Step 2:

Connect hand pulse sensor wire - front (A25) coming from main support tube to hand sensor wire - middle (A23) coming from the main frame.

Connect power wire (A26) coming from main support tube (D) to power wire (A21) coming from the main frame.

Step 3:

Secure main support tube to main frame (A1) using four bolts (N1) and four spring washers (N2) and two washers (N3). Slide main support tube cover down until it meets the main frame.

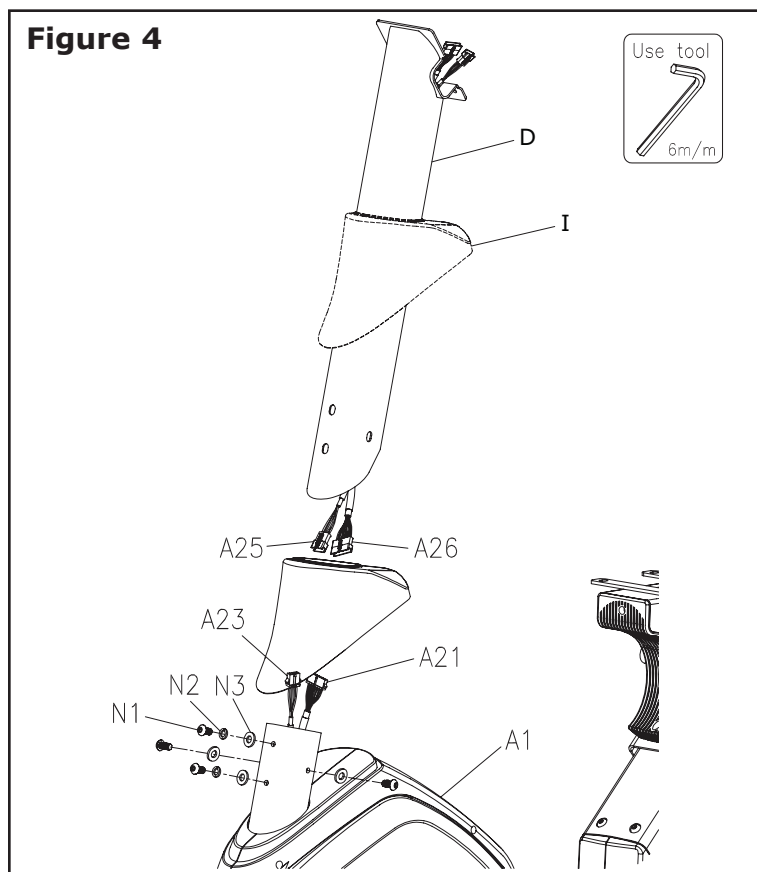

Figure 5

Step 1:

Slide the seat adjustment handlebar (A11) into the main frame and secure using stopping screw (N10).

Step 2:

Connect sensor wire (A32) to sensor wire (J1) and side handlebar (J-R) onto sliding track (A9). Secure using three bolts (N7).

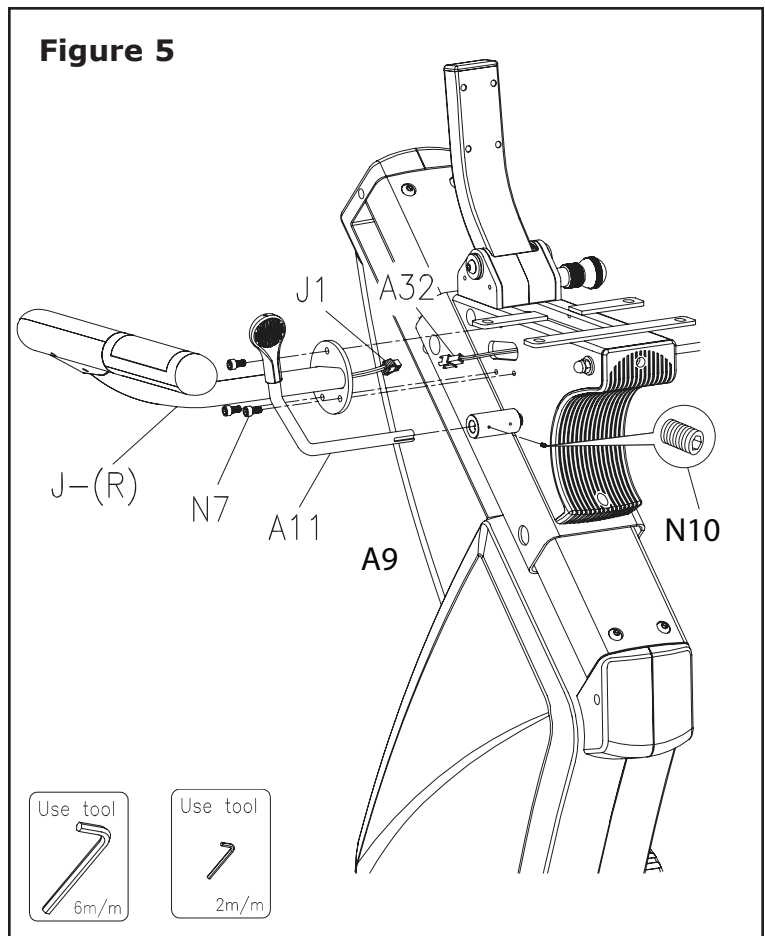

Figure 6

Step 1:

Connect sensor wires (A32) to sensor wire (J1) and side handlebar (J-L) onto sliding track (A9). Secure using three bolts (N7).

Step 2:

Locate seat pad (G) and secure onto sliding track (A9) with four screws (N1) and four washers (N3).

Note: Screws are attached underneath seat pad.

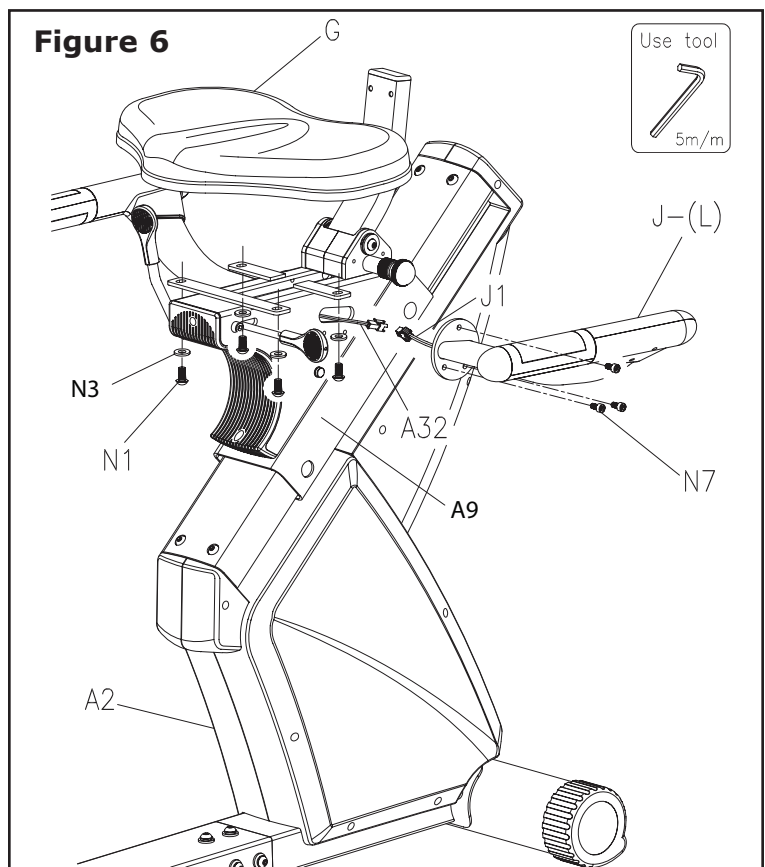

Figure 7

Step 1:

Locate backrest (H) and secure onto the backrest tube (A10) using four screws (N6).

Step 2:

Locate plastic bottle holder (K1) and secure to the middle of the main support tube (D) using two screws (K3). Place water bottle (K2) into water bottle holder (K1).

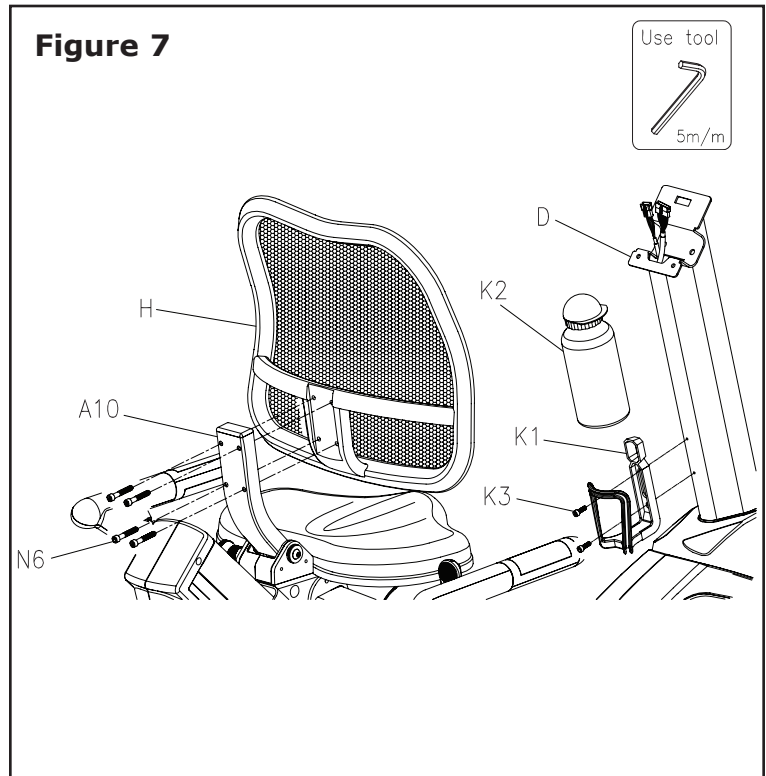

Figure 8

Step 1:

Locate small handlebar (E) and attach onto the iron plate of the console tube (D) and use two bolts (N5) and two washers (N9) to secure tightly.

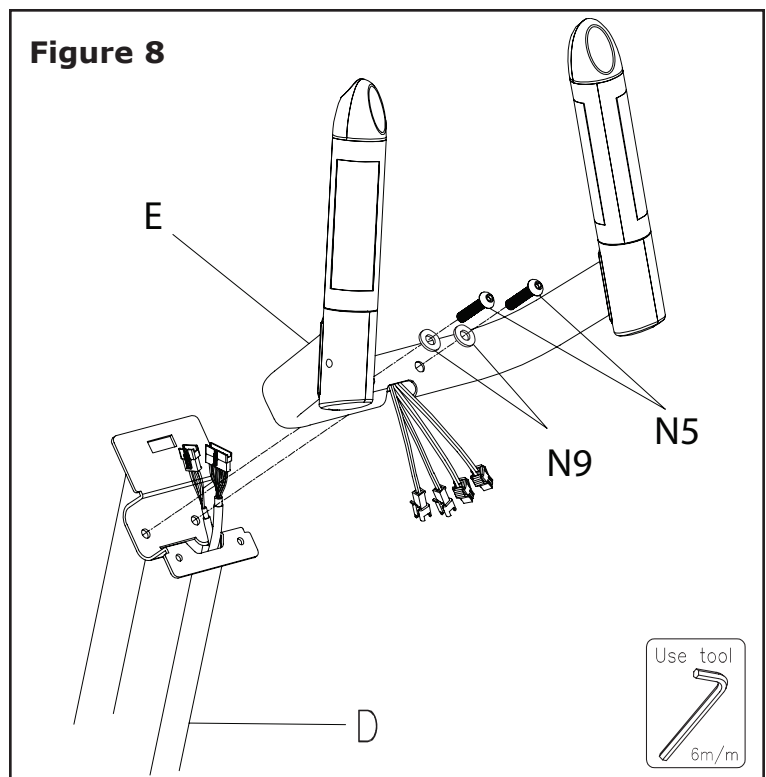

Figure 9

Step 1:

Locate console (F), and connect sensor wires (E5, A25, A26, E6, E7) to the wires coming from the console.

Step 2:

Gently push all of the wires into the console tube. Slide console onto the console tube. Secure using two screws (F1).

Note: Screws (F1) will already be attached on the backside of the console. Remove before sliding onto console tube.

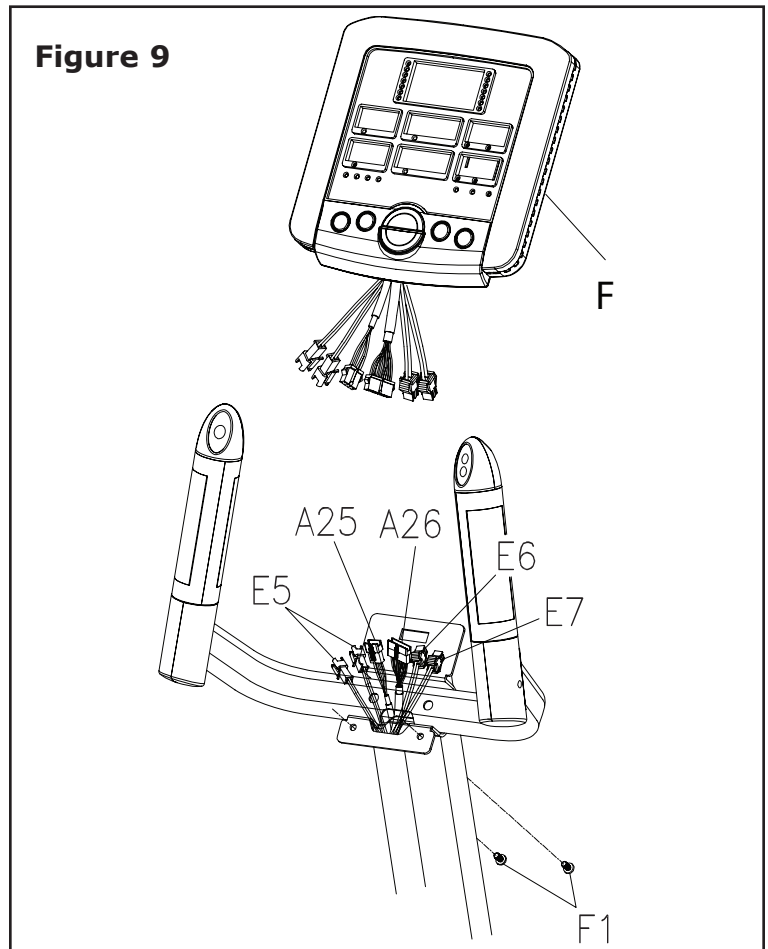

Figure 10

Step 1:

Thread the right pedal (L-R) into the right crank area of main frame (A1). Secure in place by turning it **clockwise** to tighten.

Note: Right pedal (L-R) is marked with an "R".

Step 2:

Thread the left pedal (L-L) into the left crank area of main frame (A1). Secure in place by turning it **counter-clockwise** to tighten.

Note: Left Pedal (L-L) is marked with an "L"

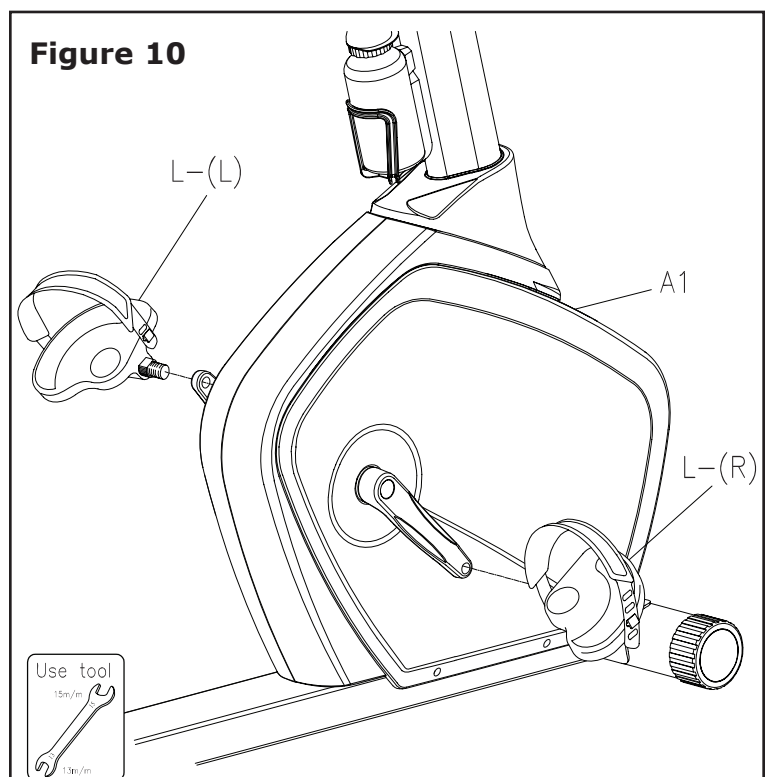

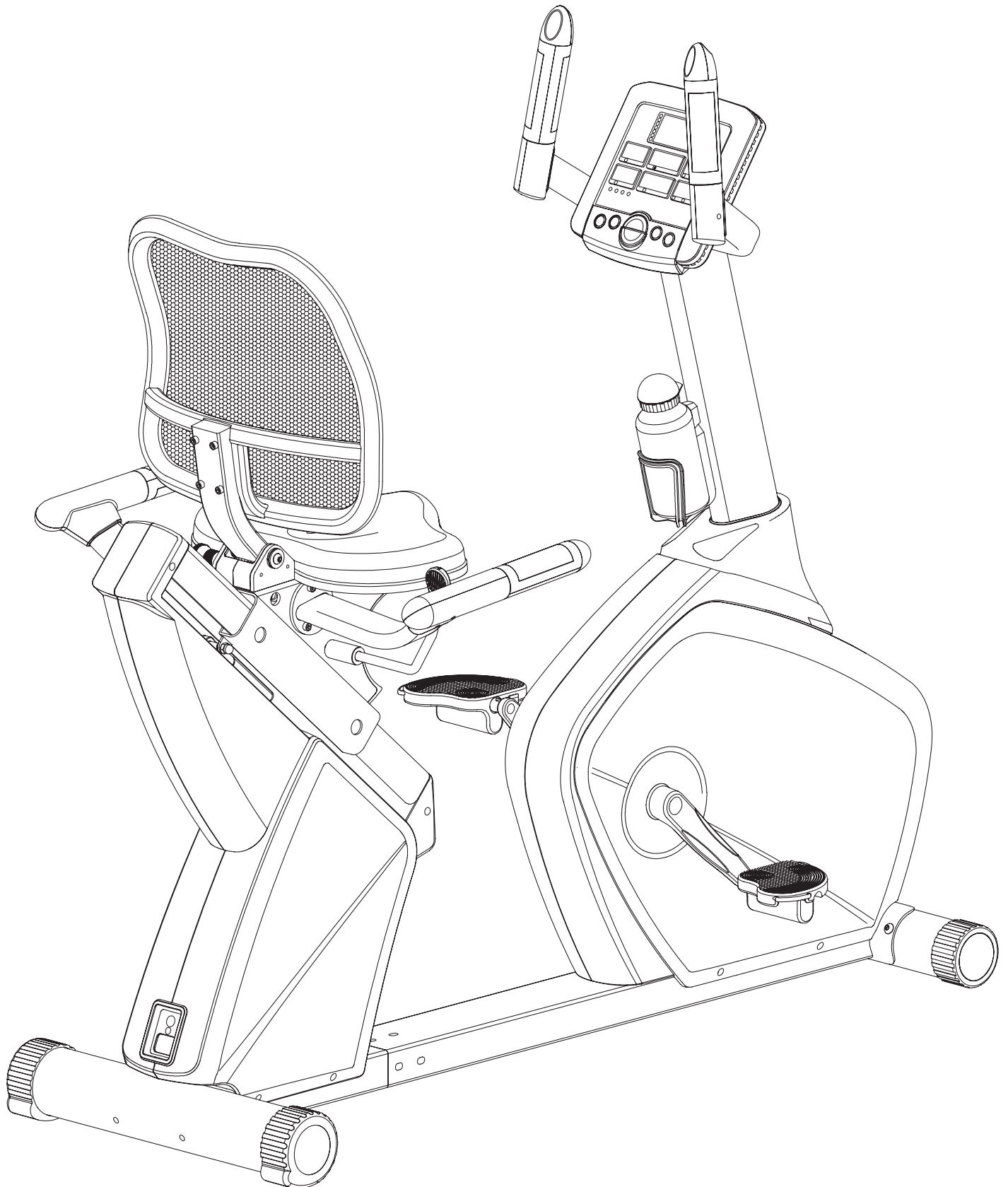

CONGRATULATIONS!
You have completed assembly of your Viper Recumbent Bike.

Console Instructions

Take a few moments to review the console layout. Below is an overview of the console and their different functions.

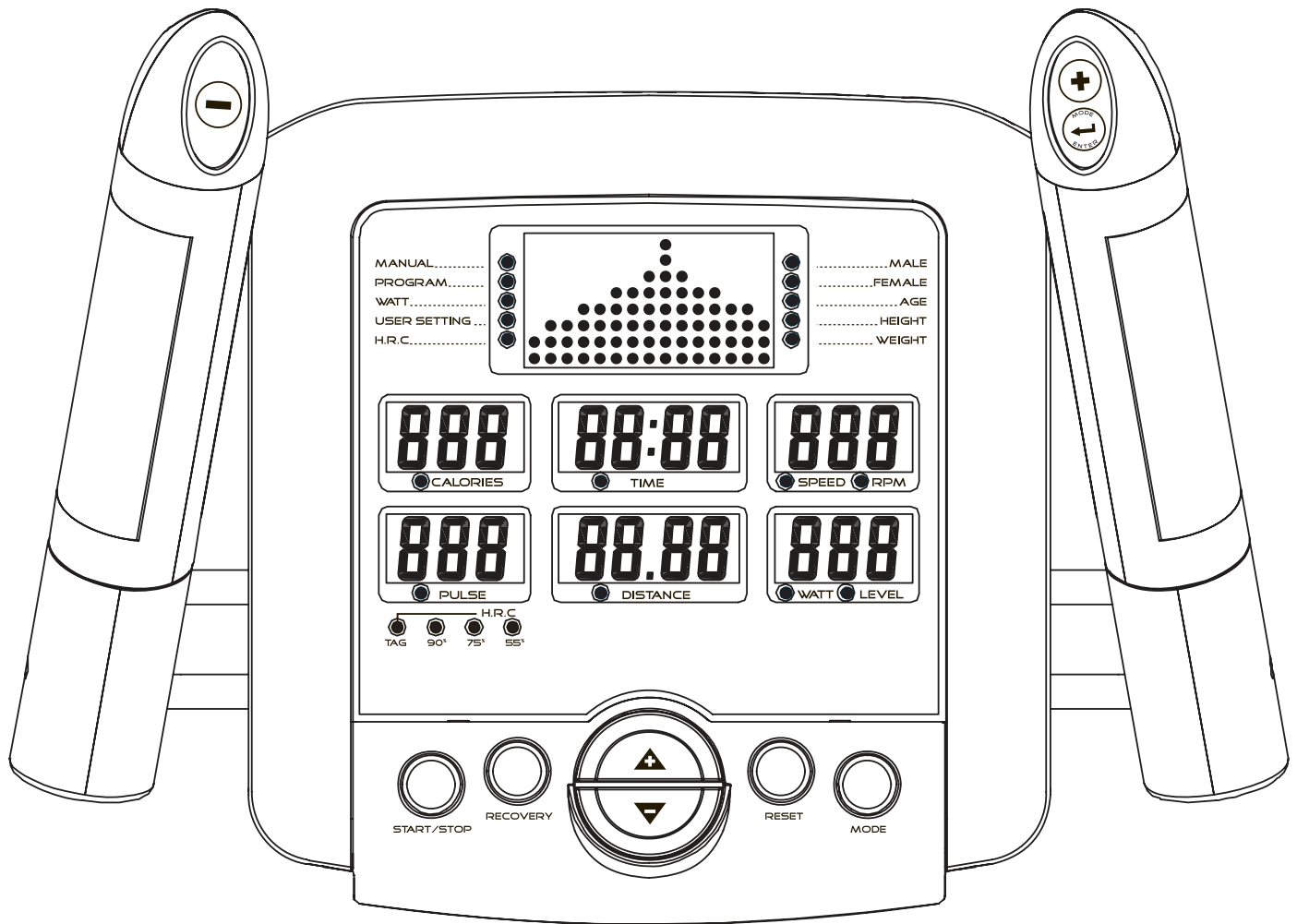

CONSOLE BUTTONS

MODE:

This button is used as an enter key, and will allow user to move to the next setting that can be changed. When pressed and held for 2 seconds or more, console will go back to the user profile selection screen.

RESET:

This button is used to return to program selection screen when workout is paused.

START/STOP:

This button is used to start or stop training.

RECOVERY:

This button is used to begin the Recovery feature of the console (refer to "Console Functions" for more information).

UP/DOWN:

When changing settings of a program, these buttons are used to increase/decrease TIME,

WEIGHT and AGE. During your workout, these buttons are used to increase/decrease the resistance level from 1 to 16. Press and hold for two seconds to rapidly increase/decrease values.

BUTTONS ON UPRIGHT HANDLEBAR

In order to offer more flexibility during your workout, additional toggle switches are placed on the upright handlebar. The buttons are the +/- and MODE. They are used the same way as the buttons on the console. These buttons may be used at anytime as a substitute to pressing the buttons located on the console.

CONSOLE FUNCTIONS

TIME:

If a target time was not selected, time will count up from 00:00 to maximum 99:59. When working out with a target time, time will count down from target to 00:00. When selecting target time, use the +/- buttons, the time will change in 1 minute increments and can range from 1:00 min to 99:00 mins.

SPEED:

Displays current training speed from 0.0 to maximum 99.9 KM or MPH.

RPM:

Displays current training revolutions per minute.

DISTANCE:

If a target distance was not selected, distance will count up from 0.00 to maximum 99.90. When working out with a target distance, distance will count down from target to 0.0. When selecting target time, use the +/- buttons, the distance will change in 0.1 mile increments and can range from 0.00 miles to 99.90 miles.

CALORIES:

If target calories were not selected, calories will count up from 0 to maximum 990. When working out with target calories, calories will count down from target to 0. When selecting target calories, use the +/- buttons, the calories will change in 10 calorie increments and can range from 0 calories to 990 calories.

PULSE:

Displays your current heart rate as soon as both hands are holding the pulse sensor. The monitor will detect your heart rate through hand grip sensors that are located on the upright and near the seat. **Note:** *It may take several seconds for the electronics to detect and display an accurate heart rate reading.*

WATT:

Displays current training watt figures. A watt is a measurement of the amount of power generated by the user based on the resistance and speed.

RECOVERY:

After your workout, keep holding on hand grips and press "RECOVERY" button. All function display will stop except "TIME" starts counting down from 01:00 to 00:00. Screen will display your heart rate recovery status rating between F1-F6. F1 is the best, F6 is the worst. User may keep exercising to improve the heart rate recovery status. (Press the RECOVERY button again to return the main display.)

GENERAL INFORMATION

1. Start pedaling or press any button to start Console.
2. The console will shut down after 4 minutes of no activity, and will display room temperature. Begin pedaling or press any button to bring console back to operational state.
3. To reset console press and hold the MODE or RESET button for 2 seconds.
4. To begin workout without inputting any values (Quick Start Mode), simply press START/STOP once the console is turned on. Change resistance during workout by pressing the +/- buttons.

Note: *The values calculated or measured by the console are for exercise purposes only, not for medical purposes.*

GETTING STARTED

When console is first turned on, user will be able to select a user profile. There are four profiles to choose from, U1-U4. Each profile allows the user to enter his/her information, such as Gender, Age, Height and Weight.

To begin, first select desired profile (U1-U4) that will be edited. Press MODE button to confirm selection. The console will now allow user to select his/her gender. Use the +/- buttons on the console or on the upper handlebars to select user's gender. Press MODE to confirm selection. Next, enter user's age. Use the +/- buttons on the console or on the upper handlebars to select user's age. Press MODE to confirm selection. The console will now allow user to enter his/her height. Use the +/- buttons on the console or on the upper handlebars to select user's height. **Note: Height will be shown in inches.** Press MODE to confirm your selection. Finally, enter user's weight. Use the +/- buttons on the console or on the upper handlebars to select user's weight. Press MODE to confirm selection. The console remembers these settings until the power is lost or disconnected, at which point, the console will revert back to default settings.

PROGRAM INSTRUCTIONS

Once profile is either created or selected, user will select the type of workout desired. The available workouts include Manual, Program, Watt, User and HRC.

MANUAL PROGRAM:

After selecting user profile, use the +/- buttons until the red light is blinking next to Manual. The manual program allows the user to manually adjust tension settings throughout his/her workout. The default tension level is 1. You may set desired time, distance, calories, resistance, distance, and pulse rate for your workout. If desired, user may bypass all of this, and simply press START/STOP button and enter into quick start mode.

Console Instructions



Time will flash in the display. Use the +/- buttons to set desired time. Press MODE to confirm selection. Repeat steps for distance, pulse, resistance, and calories. Press START/STOP to begin exercising at any time. You can change the tension level at any time during your workout session by pressing the +/- buttons.

PROGRAMS:

The console comes with 12 preset programs (see program profiles on page 17 for programs available). After selecting user profile, use the +/- buttons until Program is selected (the blinking red light will be next to the word Program). Press MODE button to confirm selection. Use the +/- buttons until desired program is blinking (P1-P12). Press MODE button to confirm selection. The console will now allow user to select the level of workout (resistance shown as L1-L10) by using the +/- buttons until the desired level is selected. Press MODE button to confirm selection. Time will flash in the display. Use the +/- buttons to set desired time. Press MODE to confirm selection. Repeat steps for distance, pulse, resistance, and calories. Press START/STOP to begin exercising at any time. You can change the level at any time during your workout session by pressing the +/- buttons.

USER PROGRAM:

The console allows user to customize a workout session. This program is divided into 15 segments. Resistance can be set for each segment. The program will be stored in the console's memory after set-up.

After selecting user profile, use the +/- buttons until User Setting is selected (the blinking red light will be next to the word User Setting). Press MODE button to confirm selection. The first segment will now be flashing in the main window. Use the +/- buttons to increase or decrease the desired resistance. Press the MODE button to confirm selection and proceed to the next segment. Repeat until all segments contain desired resistance.

HEART RATE PROGRAM (HRC):

Heart rate control programs are designed to automatically change resistance to keep your heart rate at a predetermined level based on the selected Heart Rate program. Each heart rate program is designed with a specific goal in mind. **Note:** *This calculation is based on your age which must be entered correctly into your user profile.*

Program	Goal
55% HRC	Weight Loss
75% HRC	Cardio
90% HRC	Performance
TRG HRC	Custom

See **MONITORING YOUR HEART RATE** section for more information.

After selecting user profile, use the +/- buttons until Program is selected (the blinking red light will be next to the word Program). Press MODE button to confirm selection. Use +/- to select desired HRC Program. There are four different programs - heart rate 55% HRC (Heart Rate Control), 75% HRC, 90% HRC, and Target HRC (user specifies the percentage of maximum heart rate desired). Press MODE button to confirm selection.

Console Instructions



If TRG is selected, use the +/- buttons until desired target heart rate is selected. Press MODE button to confirm selection.

Time will flash in the display. Use the +/- buttons to set desired time. Press MODE to confirm selection. Repeat steps for distance, pulse, resistance, and calories. Press START/STOP to begin exercising at any time.

Note: For a more accurate reading, hold the hand grips with both hands. This is especially important in Heart Rate Mode.

PROGRAM PROFILES

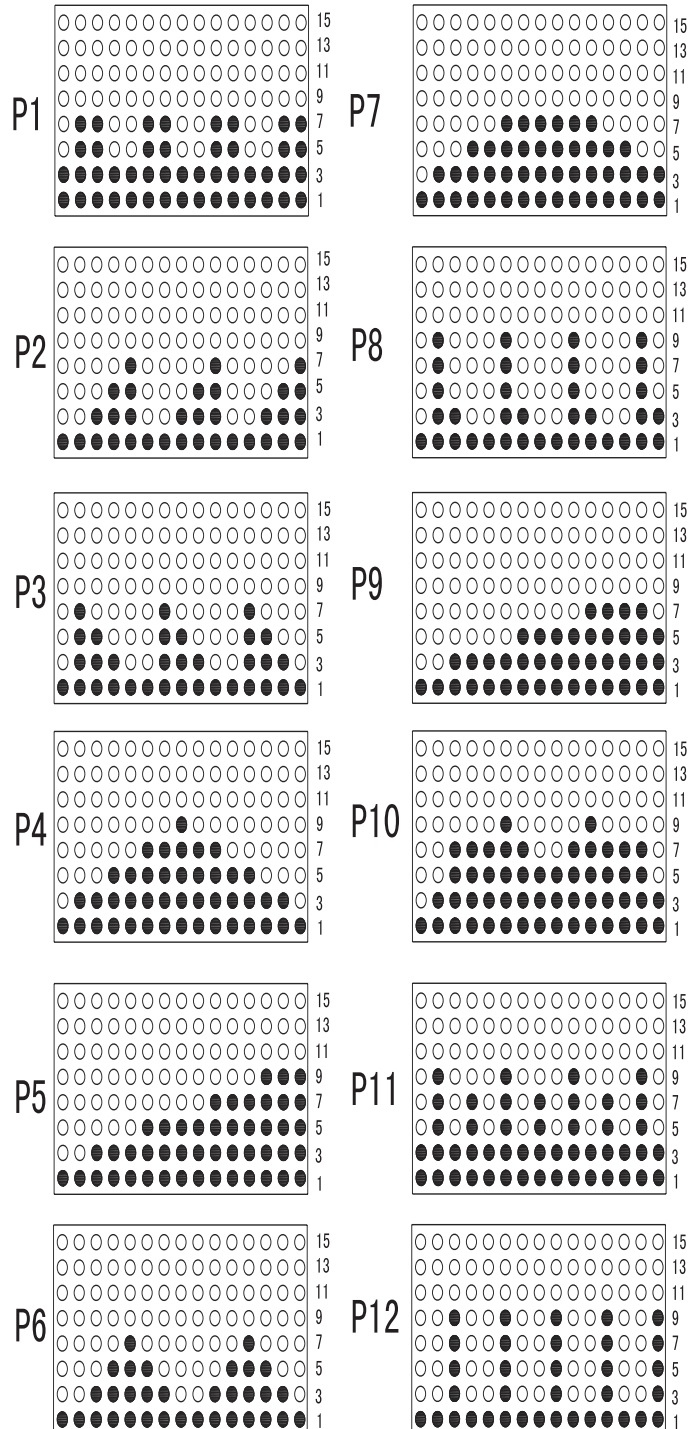

Monitoring Your Heart Rate

Monitoring Your Heart Rate

To obtain the greatest cardiovascular benefits from your exercise workout, it is important to work within your target heart rate zone. The American Heart Association (AHA) defines this target as 60%-75% percent of your maximum heart rate.

Your maximum heart rate may be roughly calculated by subtracting your age from 220. Your maximum heart rate and aerobic capacity naturally decreases as you age. This may vary from one person to another, but use this number to find your approximate effective target zone. For example, the maximum heart rate for an average 40 year-old is 180 bpm. The target heart rate zone is 60%-75% of 180 or 108-135 bpm. See **Fitness Safety** below.

Before beginning your workout, check your normal resting heart rate. Place your fingers lightly against your neck, or against your wrist over the main artery. After finding your pulse, count the number of beats in 10 seconds. Multiply the number of beats by six to determine your pulse rate per minute. We recommend taking your heart rate at these times; at rest, after warming up, during your workout and two minutes into your cool down, to accurately track your progress as it relates to better fitness.

During your first several months of exercising, the AHA recommends aiming for the lower part of the target heart rate zone-60%, then gradually progressing up to 75%. According to the AHA, exercising above 75% of your maximum heart rate may be too strenuous unless you are in top physical condition. Exercising below 60% of your maximum will result in minimal cardiovascular conditioning.

Check your pulse recovery rate – If your pulse is over 100 bpm five minutes after you stop exercising, or if it's higher than normal the morning after exercising, your exertion may have been too strenuous for your current fitness level. Rest and reduce the intensity next time.

Fitness Safety *The Heart Rate chart indicates average rate zones for different ages. A variety of different factors (including medication, emotional state, temperature and other conditions) can affect the target heart rate zone that is best for you. Your physician or health care professional can help you determine the exercise intensity that is appropriate for your age and condition.*

(MHR) = Maximum Heart Rate
 (THR) = Target Heart Rate

220 - age = maximum heart rate (MHZ)
 MHZ x .60 = 60% of your maximum heart rate.
 MHZ x .75 = 75% of your maximum heart rate.
 For example, if you are 30 years old, your calculations will be as follows:

220 - 30 = 190
 190 x .60 = 114 (low end or 60% of MHZ)
 190 x .75 = 142 (high end or 75% of MHZ)
 30 year-old (THR) Target Heart Rate would be 114-142

Warm Up Exercises

EXERCISE GUIDELINES

WARNING! Before beginning this or any exercise program, you should consult your physician. This is especially important for individuals over the age of 35 or individuals with pre-existing health problems.

Warming up prepares the body for the exercise by increasing circulation, supplying more oxygen to the muscles and raising body temperature. Begin each workout with 5 to 10 minutes of stretching and light exercise to warm up. The photos on this page show several forms of basic stretching you may perform before your workouts. In order to achieve an adequate warm-up, perform each stretch three times.

TOE TOUCH STRETCH

Stand, bending your knees slightly and slowly bend forward from your hips. Allow your back and shoulders to relax as you reach down toward your toes as far as possible. Hold for 15 counts, then relax. This will stretch your hamstrings, back of knees, and back.

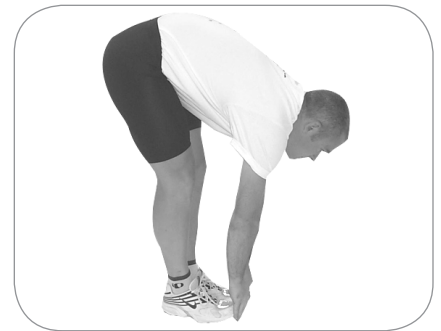

HAMSTRING STRETCH

Sit with one leg extended. Bring the sole of the opposite foot toward you and rest it against the inner thigh of your extended leg. Reach toward your toes as far as possible. Hold for 15 counts, then relax. This will stretch your hamstrings, lower back, and groin.

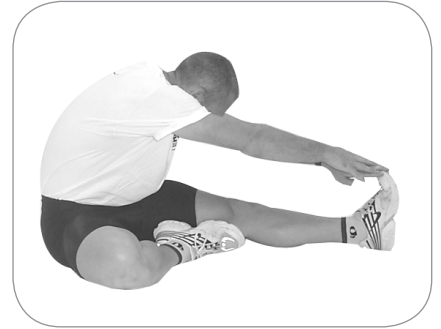

CALF/ACHILLES STRETCH

With one leg in front of the other, reach forward and place your hands against a wall. Keep your back leg straight and your back foot flat on the floor. Bend your front leg, lean forward and move your hips toward the wall. Hold for 15 counts, then relax. To cause further stretching of the Achilles tendon, bend your back leg as well. This will stretch your calves, Achilles tendons, and ankles.

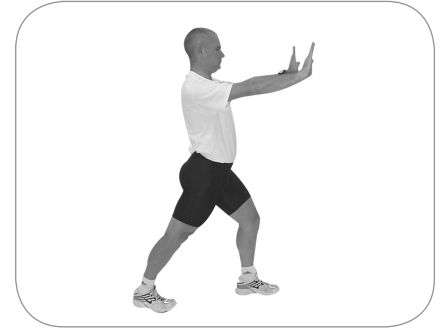

QUADRICEPS STRETCH

With one hand against a wall for balance, reach back and grasp one foot with your other hand. Bring your heel as close to your buttocks as possible. Hold for 15 counts, then relax. This will stretch your quadriceps and hip muscles.

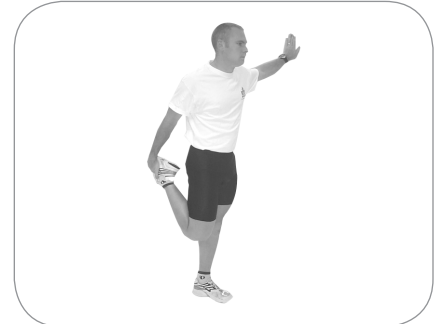

INNER THIGH STRETCH (Image not Shown)

Sit with the soles of your feet together and your knees outward. Pull your feet toward your groin area as far as possible. Hold for 15 counts, then relax. This will stretch your quadriceps and hip muscles.

How To Use The Seat Adjustment Bar To Find A Proper Seat Position

Push the seat slide adjustment handle forward, then slide the seat up and down until desired position is found. When desired position is found, pull the adjustment handle back into the upward position.

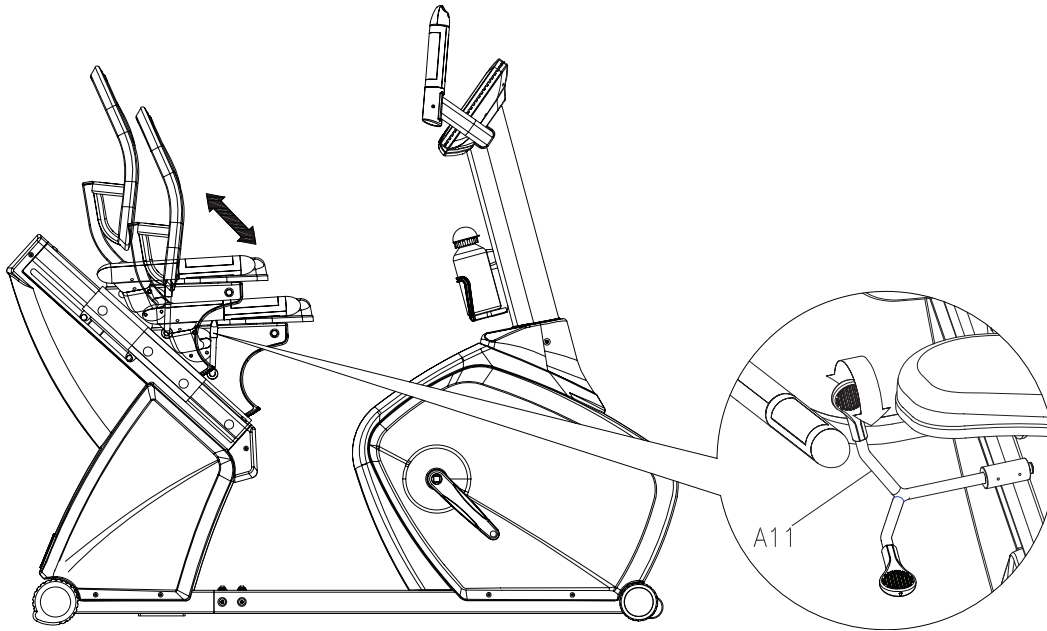

How To Adjust The Backrest

Push the bar located underneath the seat backward to adjust the backrest to desired position. Release the bar when desired position is found.

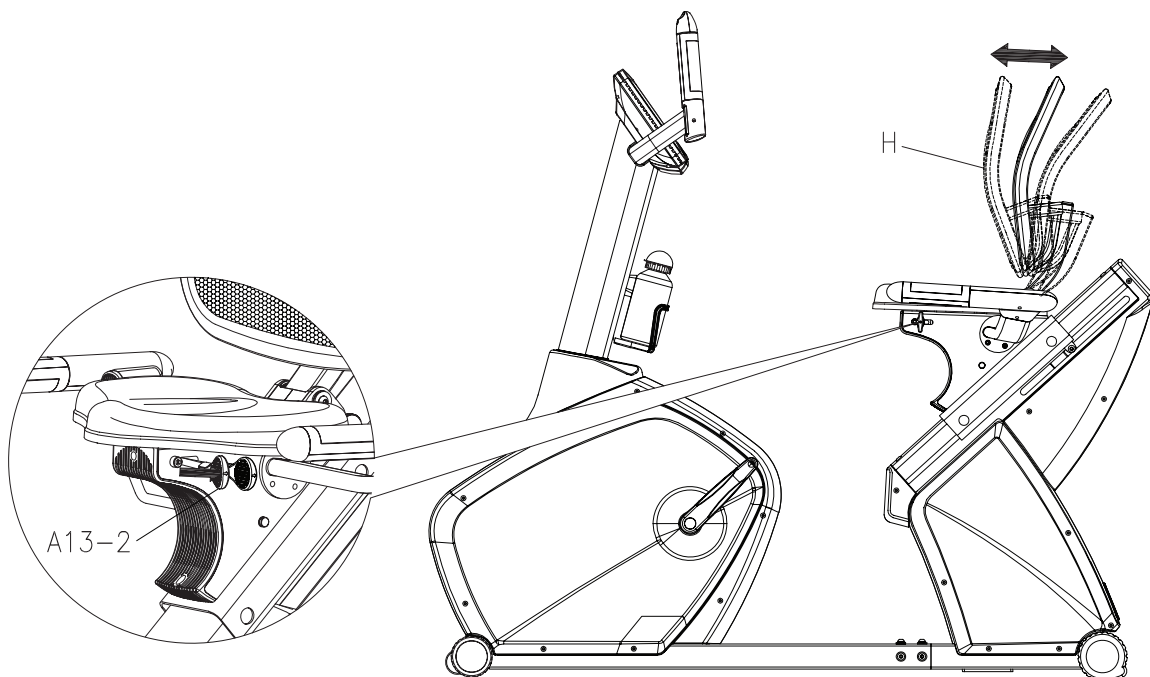

Moving Instructions

Caution! To reduce the possibility of injury while lifting, bend your legs and keep your back straight. As you lean the unit, lift using your legs, not your back.

First, kneel down and grasp the rear support tube with both hands. Next, with a firm grasp on rear support tube stand up bringing the rear of the bike up in the air and tilt the unit until it rolls freely on the transport wheels. Using extreme caution, move the unit to the desired location. Do not attempt to move the unit over an uneven or rough surface.

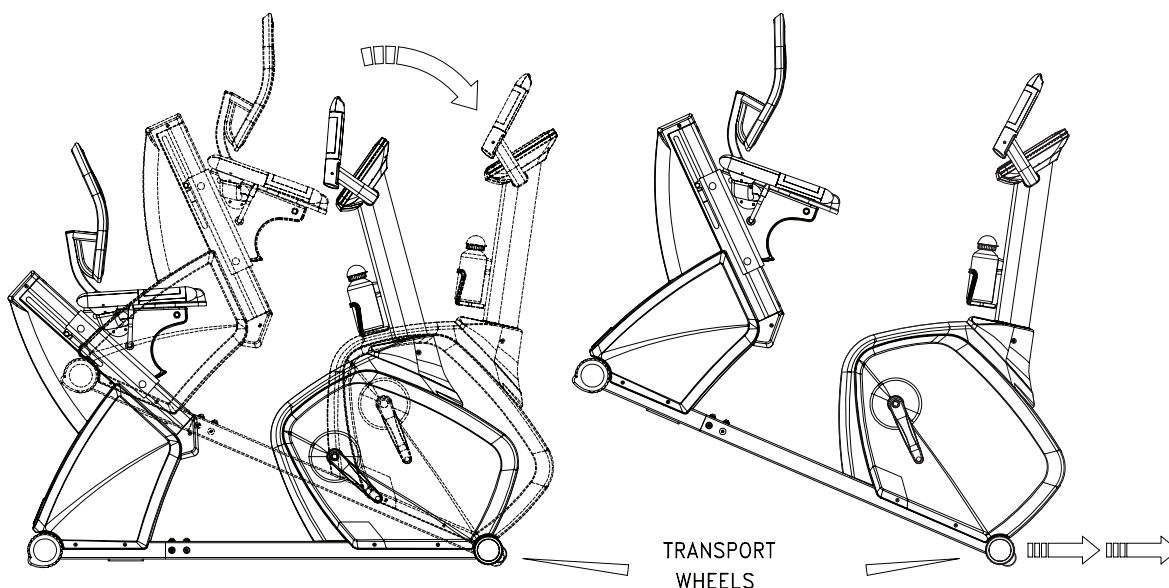

Note: This unit may not be identical to your unit.

Parts List



Viper Recumbent Bike Parts List Rev B

Ref #	Parts #	DESCRIPTION	Qty	Ref #	Parts #	Description	Qty
A1	323-00586	FRONT MAIN FRAME	1	A29	302-01538	SCREW, HEXAGON 8X25MM	2
A2	323-00592	REAR MAIN FRAME	1	A30	319-00386	COVER, FOR CRANK	2
A3	319-00382	ALUMINUM TRACKING	1	A31	313-00426	POWER CORD FRONT	1
A4	306-00975	FRONT LEFT CHAIN COVER	1	A32	313-00427	POWER CORD REAR	1
A5	306-00976	FRONT RIGHT CHAIN COVER	1	A32-1	302-01561	NUT A32-1	1
A6	319-00391	REAR LEFT CHAIN COVER	1	A33	306-00959	COVER, DECORATION FOR CORD STAND	1
A7	319-00392	REAR RIGHT CHAIN COVER	1	A34	302-01563	SCREW, HEXAGON 4X12MM	1
A8	306-00965	COVER, FOR SLIDING TRACKING	1	A35	305-00233	SENSOR PIPE HOUSING	1
A9	319-00394	SLIDING TRACK	1	A36	302-01537	SCREW, FIXING A36	1
A9-1	306-00974	WHEEL	4	A37	302-01541	WASHER, FLAT A37	2
A9-2	302-01536	SCREW, FIX FOR WHEEL-A9-2	4	A38	302-01565	NUT, NYLON A38	3
A9-3	302-01560	METAL BUSHING, A9-3	2	A39	302-01535	SCREW, CROSS FOR MOTOR A39	4
A9-4	310-00247	FIXING PIN	1	A40	302-01543	SCREW, HEXAGON A40	1
A9-5	302-01571	SPRING A9-5	1	A41	302-01548	SCREW, HEXAGON A41	1
A9-6	302-01564	NUT M16 A9-6	1	A42	302-01534	SCREW, CROSS-A42	2
A9-7	323-00598	PULL BAR	1	A43	302-01556	SCREW, HEXAGON A43	6
A9-8	306-00966	END CAP	1	A44	302-01576	SCREW, TAPPING A44	34
A9-9	306-00980	LEFT DECORATION FOR REAR TUBE	1	A45	302-01546	SCREW, HEXAGON A45	1
A9-10	306-00981	RIGHT DECORATION FOR REAR TUBE	1	A46	302-01549	SCREW, HEXAGON A46	1
A10	323-00580	BACKREST TUBE	1	A47	302-01645	SCREW, HEXAGON M4X20MM	4
A10-1	319-00412	AXLE FOR BACKREST TUBE	1	A48	302-01646	SCREW, HEXAGON M4X12MM	6
A10-2	302-01542	WASHER FLAT A10-2	2	A49	302-01647	SCREW, HEXAGON 8X5/8	4
A10-3	306-00967	END CAP FOR BACKREST TUBE	1	A50	302-01648	SCREW, HEXAGON M8X70MM	1
A11	323-00581	SEAT ADJUSTMENT HANDLE	1	A51	302-01649	WASHER, FLAT M8X16X1.2	2
A11-1	306-00979	PLASTIC WRAP	1	A52	302-01650	WASHER, FLAT 17X22X.3	2
A11-2	305-00232	CONNECTING HOUSING	1	A53	302-01651	WASHER, FLAT M6X16X1.2	1
A11-4	319-00384	AXLE FOR BRAKING	1	B1	323-00597	FRONT STABILIZER	1
A11-5	302-01527	BUSHING-L A11-5	1	B2	306-00968	END CAP FOR FRONT TUBE	1
A11-6	302-01528	BUSHING-R A11-6	1	B3	306-00973	TRANSPORATION WHEEL	2
A11-7	328-00081	BRAKE PAD	1	C1	323-00593	REAR STABILIZER	1
A11-8	319-00385	BRAKING STOPPER	1	C2	306-00970	END CAP FOR REAR TUBE LEFT	1
A11-9	302-01574	SCREW, STOPPING A11-9	2	C3	306-00969	END CAP FOR REAR TUBE RIGHT	1
A11-10	302-01532	C CLIP- A11-10	1	D	306-00977	MAIN SUPPORTING TUBE	1
A12	310-00245	GAS CYLINDER, FOR TRACKING BASE ADJUST	1	E	323-00587	FRONT SMALL HANDLE BAR	1
A12-1	302-01579	PLASTIC BUSHING	2	E1-1	323-00589	COVER, FOR LEFT HANDLE BAR LEFT	1
A13	310-00246	GAS CYLINDER, FOR BACKREST ADJUST	1	E1-2	323-00590	LEFT HANDLE BAR COVER RIGHT	1
A13-1	302-01578	PLASTIC BUSHING	2	E2-1	305-00235	RIGHT HANDLE BAR COVER(L)	1
A13-2	310-00248	GAS CYLINDER BAR	1	E2-2	305-00234	RIGHT HANDLE BAR COVER @	1
A13-3	306-00978	PLASTIC WRAP	1	E2-3	302-01652	SCREW, HEXAGON M3X15MM	2
A13-4	302-01544	SCREW, HEXAGON A13-4	1	E3-1	323-00584	CONTROLLER FOR LEFT HANDLE BAR FRONT	1
A13-5	302-01562	NUT, A13-5	2	E3-2	323-00583	CONTROLLER FOR LEFT HANDLE BAR BACK	1
A14	311-00104	FLYWHEEL	1	E3-3	307-00730	PLASTIC CIRCUIT BOARD LEFT	1
A14-1	302-01655	WASHER, FLAT 10X13X.3	7	E4-1	323-00585	CONTROLLER FOR RIGHT HANDLE BAR FRONT	1
A14-2	302-01656	WASHER, FLAT 30X34X.8	1	E4-2	323-00582	CONTROL FOR RIGHT HANDLE BAR REAR	1
A14-3	302-01531	C CLIP-A14-3	2	E4-3	307-00731	PLASTIC CIRCUIT BOARD RIGHT	1
A14-4	302-01539	NUT, FLANGE A14-4	2	E5	313-00424	HAND PULSE SENSOR WIRE	2
A14-5	302-01638	NUT, FLANGE 3/8X3T	1	E6	313-00430	SENSOR WIRE LEFT	1
A14-6	302-01639	NUT, FLANGE 3/8X5T	1	E7	313-00431	SENSOR WIRE RIGHT	1
A15	319-00390	PRESSING PIPE	1	E8-1	313-00420	HAND PULSE	8
A15-1	302-01567	PRESSING SPRING A15-1	1	E8-2	328-00082	PAD FOR HAND PULSE	8
A15-2	331-00118	BEARING	2	E8-3	302-01568	SCREW E8-3	8
A15-3	319-00389	PIPE	3	E9	302-01569	SCREW E9	2
A15-4	302-01540	WASHER, FLAT A15-4	3	F	307-00729	MONITOR	1
A15-5	302-01547	SCREW, HEXAGON A15-5	3	F1	302-01533	SCREW, CROSS-F1	2
A15-7	302-01529	C CLIP C12	1	G	328-00084	SEAT, VIPER	1
A15-8	302-01641	WASHER M6X19X1.5	1	H	323-00579	BACKREST	1
A16	302-01559	HOUSING-MAGNET A16	1	I	306-00962	COVER, FOR MAIN SUPPORTING TUBE	1
A16-1	302-01570	SPRING A16-1	1	J-(L)	323-00591	LEFT SIDE HANDLE BAR	1
A16-2	302-01580	TENSION CABLE, VIPER	1	J-(R)	323-00596	HANDLE BAR, FOR RIGHT SIDE	1
A16-3	302-01642	SCREW, HEXAGON M6X60MM	1	J1	313-00423	HAND PULSE SENSOR WIRE	2
A16-4	302-01643	NUT, FLANGE M6	1	J2-1	306-00961	COVER, HANDLE BAR UPPER LEFT	1
A16-5	302-01644	NUT, FLANGE M6	1	J2-2	306-00960	COVER, HANDLE BAR DOWN LEFT	1
A17	302-01526	BELT PULLEY A17	1	J3-1	306-00964	COVER, HANDLE BAR UPPER RIGHT	1
A17-1	319-00383	AXLE FOR BELT PULLEY	1	J3-2	306-00963	COVER, HANDLE BAR DOWN RIGHT	1
A17-2	302-01530	C CLIP- A17-2	2	J4	306-00971	END CAP FOR SIDE HANDLE BAR	2
A17-3	302-01558	MAGNET A17-3	1	K1	302-01632	BOTTLE HOLDER, VIPER	1
A17-4	302-01550	SCREW, HEXAGON A17-4	4	K2	302-01633	BOTTLE HOLDER, VIPER	1
A17-5	304-00030	BELT 6PJ 46	1	K3	302-01634	SCREW M8*9.5, VIPER	2
A17-6	302-01566	NUT, NYLON A17-6	4	M	313-00419	ADAPTOR	1
A18	331-00119	BEARING	2	N1	302-01545	SCREW, HEXAGON N1	16
A19	306-01023	END CAP 40X80MM	1	N2	302-01572	WASHER, SPRING N2	6
A20	306-01024	END CAP 40X100MM	1	N3	302-01577	WASHER N3	6
A21	307-00732	MOTOR, VIPER	1	N4	302-01551	SCREW, HEXAGON N4	2
A22	313-00429	SENSOR WIRE	1	N5	302-01553	SCREW, HEXAGON N5	2
A23	313-00421	HAND PULSE SENSOR MIDDLE	1	N6	302-01552	SCREW, HEXAGON N6	4
A24	313-00422	HAND PULSE SENSOR REAR	1	N7	302-01555	SCREW, HEXAGON N7	6
A25	313-00425	HAND PULSE SENSOR FRONT	1	N8	302-01653	SCREW, HEXAGON M8X20MM	2
A26	313-00428	SENSOR WIRE	1	N9	302-01654	WASHER, FLAT M6X8MM	2
A27	319-00387	CRANK LEFT	1	N10	302-01575	SCREW, HEXAGON M6X8MM	1
A28	319-00388	CRANK RIGHT	1	#	302-01582	BOLT PACK, VIPER	1

Exploded View

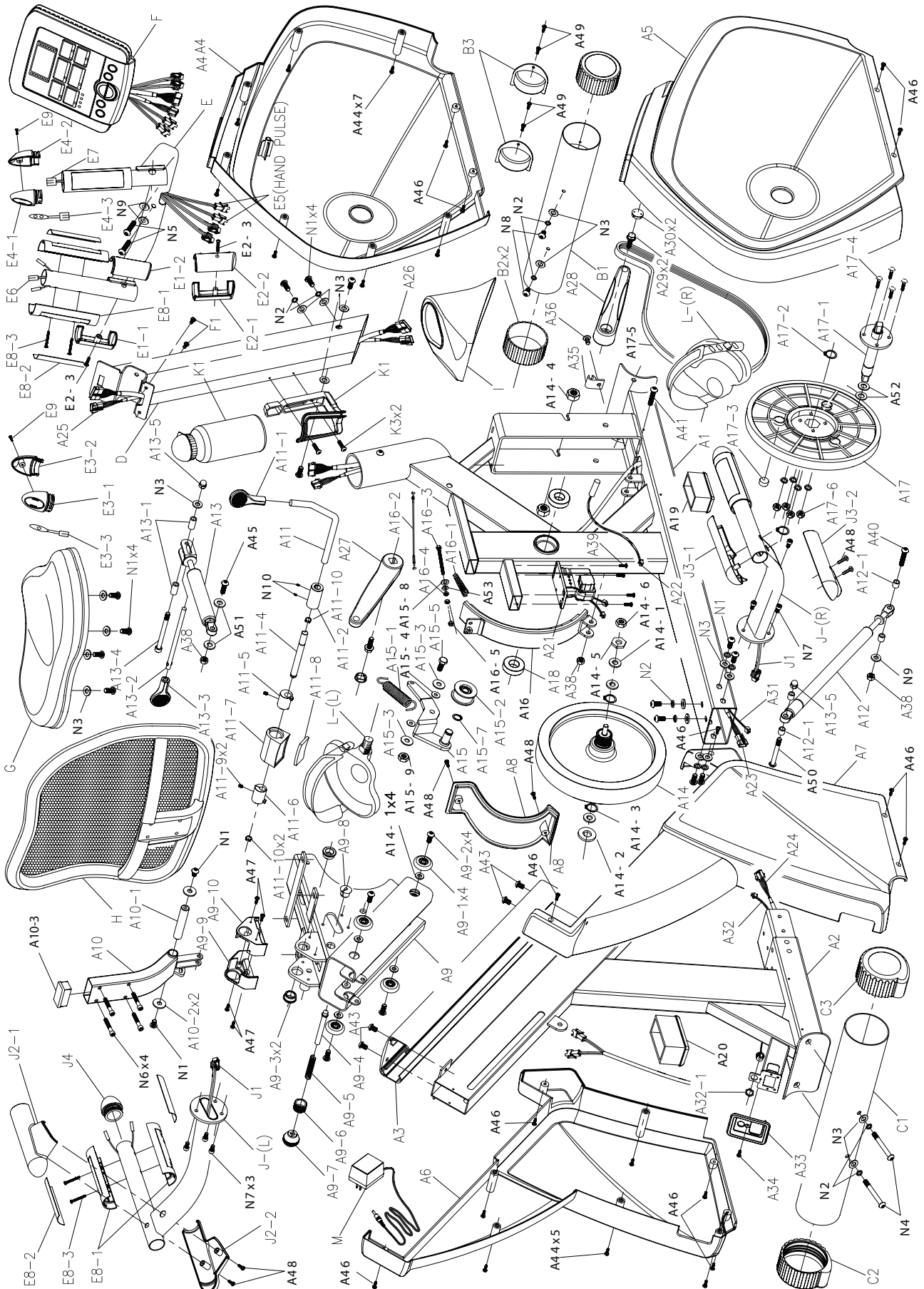

Warranty Information



Residential and Personal Use Limited Warranty

PLEASE READ THESE WARRANTY TERMS AND CONDITIONS FULLY AND CAREFULLY BEFORE USING YOUR IRONMAN FITNESS EQUIPMENT. BY USING THE EQUIPMENT, YOU ARE CONSENTING TO BE BOUND BY THE FOLLOWING TERMS AND CONDITIONS.

Frame: Lifetime

Electronics and *Parts: 1 yr

Missing/Cosmetic Parts: 30 Days

Limited Warranty

This Limited Warranty applies in the United States and Canada to Products manufactured or distributed by Ironman Fitness Products, L.P. under the Ironman Fitness ("Ironman") brand name (as used herein, the "Product" or "Products"). The warranty period to the original purchaser is listed above, and commences on the date of original purchase of the product, unless otherwise authorized by Ironman. Ironman warrants that the Product purchased from Ironman or from an authorized Ironman Fitness reseller "dealer" (for residential or personal use only, unless otherwise authorized by Ironman in writing), is free from defects in Materials and Workmanship relevant to the functionality of the Product at *initial startup*, under normal use, and during the applicable warranty period, unless otherwise determined by Ironman.

This warranty excludes *expendable parts* if primary cause for warranty claim is wear. *Expendable parts* pertain to components on the Product that are prone to normal wear and tear. These items vary by Product, and can include (but not limited to) hand grips, skid pads, pedals, pedal straps, poly-v belts, console overlays, toggle switch/button overlays, (luster free or dull) ekg plates, decals, and any other items that are not essential to the operation of the Product, unless otherwise determined by Ironman.

This warranty extends only to you, the original purchaser. It is not transferable to anyone who subsequently purchases (or receives as a gift) the Product from you. Your sales receipt, showing the date/place of purchase and serial number (if applicable) of the Product, is your proof of purchase, and may be required by Ironman any time a warranty parts (or service) claim is made or if no warranty record exists for the product.

Exclusive Remedies

During the warranty period listed above, Ironman will repair a Product by correcting any minor issues (either by phone or online support) that might be causing the Product failure. Should a technical service and support representative be unable to correct the issue, Ironman may replace the parts (with new parts or at the option of Ironman, with serviceable used parts, that are equivalent to new parts in performance) that become defective, malfunction, or otherwise fail to conform to this Limited Warranty under normal use.

Replacement parts shall be warranted for 30 days from the shipment reception date or through the end of the 'replaced' part warranty period, whichever is longer. Any replacement parts, required *past the warranty period* listed above, shall be subject to purchase at retail price, plus any added shipping and handling charges associated to the delivery of the part. Note that replacement parts may be available only through the lifetime (as defined) of the Product. In conforming to this warranty, Ironman (as the manufacturer) reserves the right to change manufacturers or vendors of any part to cover the existing warranty.

Ironman may also provide service (if deemed necessary and if applicable) at no charge to you during (and not to exceed) the service warranty period listed above, in an attempt to repair the Product. Should the Product require service at your request or out of the limited warranty period, Ironman can furnish contact information for local (to your area) Ironman authorized service providers. Service quotes, costs, and scheduling will be strictly dependent on service provider rates and mutual (consumer/provider) service agreements. Ironman is not responsible for any service repair costs accrued through the use of authorized Ironman service providers at your request or out of the limited warranty period (without written consent from Ironman), beyond the limitations outlined on this warranty.

Replacements and Returns

If after a reasonable number of attempts, a defect has not been repaired (or the Product is deemed non-repairable by Ironman technical service and support staff), Ironman, based on a case by case review, may opt to replace the Product, or recommend an alternate resolution, such as a warranty buy-out (Product cost, subject to deduction of a reasonable charge for usage) or a credit. Ironman, as a manufacturer, reserves the right to replace the Product with a Factory-Reconditioned Product that meets or exceeds standards comparable to those of the replaced Product.

The warranty covering the replacement Product shall expire on the date the original warranty for the replaced Product would have expired, unless otherwise determined by Ironman.

Conditions and Restrictions

This warranty **DOES NOT** (A) cover shipping and handling charges, export taxes, custom duties and taxes, or any other charges associated with transportation of the parts or Product, beyond the initial courtesy period of 60 days from original date of purchase of the Product; (B) extend to Products not purchased from Ironman or from an authorized Ironman reseller; (C) extend to Products purchased from online auction sites; (D) cover any extended, additional, or third party warranties if not offered exclusively by Ironman in writing; (E) cover Products installed at fee based facilities/commercial environments (gyms, homes used as wellness centers, etc.); (F) cover Products installed in light institutional environments (non fee-based facilities include for example, and not be way of limitation, fire houses, police departments, rehab centers, hospitals, clinics, apartment complexes, club houses, etc.); (G) cover service calls to correct installation, perform maintenance, or instruct owners on how to use the equipment; or (H) cover a Product on which the serial number has been purposefully or accidentally defaced or removed and there is no proof of purchase available (if serial number is applicable), unless authorized by Ironman in writing or otherwise stated on this warranty.

This Limited Warranty becomes void for Products that have been damaged or rendered defective as a result of (a) accident, misuse, or abuse (including but not limited to exceeding the Ironman listed, maximum weight limit); (b) use of parts not manufactured or sold by Ironman; (c) modification of the Product; (d) normal wear and tear; (e) operation on incorrect power supplies; (f) ***failure to perform (or performing improper) maintenance; (g) service by anyone other than Ironman, or an authorized Ironman warranty service provider; (h) floods, fires, earthquakes, lightning strikes, power surges, and other unavoidable acts of nature; (j) residential mis-wires; or (k) incorrect setup, installation, or assembly. Should any Product (submitted for warranty parts replacement) be found ineligible under the terms outlined on this warranty, an estimate for parts purchase (if available) can be furnished at your request.

***Parts** is herein defined exclusively, for all intents and purposes, and pertaining to this Limited Manufacturer Warranty, as components or Materials essential to the functionality of the Product.

****Lifetime** of a Product, is herein defined exclusively, for all intents and purposes, and pertaining to this Limited Manufacturer Warranty, as the time period 7 years beyond the end of production cycle of a Product in question.

Disclaimer and Release

EXCEPT AS EXPRESSLY SET FORTH IN THIS WARRANTY, IRONMAN MAKES NO OTHER WARRANTIES, EXPRESSED OR IMPLIED, INCLUDING ANY IMPLIED WARRANTIES OF MERCHANTABILITY AND FITNESS FOR A PARTICULAR PURPOSE. IRONMAN EXPRESSLY DISCLAIMS ALL WARRANTIES NOT STATED IN THIS LIMITED WARRANTY. ANY IMPLIED WARRANTIES THAT MAY BE IMPOSED BY LAW ARE LIMITED TO THE TERMS OF THIS LIMITED WARRANTY. NEITHER IRONMAN NOR ANY OF ITS AFFILIATES SHALL BE RESPONSIBLE FOR INCIDENTAL OR CONSEQUENTIAL DAMAGES. SOME STATES DO NOT ALLOW LIMITATIONS ON IMPLIED WARRANTIES OR THE EXCLUSION OR LIMITATION OF INCIDENTAL OR CONSEQUENTIAL DAMAGES, SO THE ABOVE LIMITATIONS OR EXCLUSIONS MAY NOT APPLY TO YOU. THIS LIMITED WARRANTY GIVES YOU SPECIFIC LEGAL RIGHTS AND YOU MAY ALSO HAVE OTHER RIGHTS THAT MAY VARY FROM STATE TO STATE. THIS IS THE ONLY EXPRESS WARRANTY APPLICABLE TO IRONMAN-BRANDED PRODUCTS. IRONMAN NEITHER ASSUMES NOR AUTHORIZES ANYONE TO ASSUME FOR IT ANY OTHER EXPRESS WARRANTY.



**Customer Service
1.800.750.IRON
1.800.750.4766**

**Ironman Fitness
4009 Distribution Drive
Suite 250
Garland, TX 75041**

www.ironmanfitness.com